



APPLICATION

- For all seagoing vessels with a length of 20 metres or more
- For all vessels in Rhine and (European) Inland navigation
- NATO codification

MATERIALS

- Matt black polyamide and polycarbonate, reinforced with fibreglass
- Corrosion-free, seawater resistant, non-magnetic
- Fresnel polycarbonate lens, shock resistant, interchangeable

WIRING

- 1,5 metre neoprene cable H07 RN 2x1.5
- Cable gland Pg13

PROTECTION CLASS

IP56

MOUNTING

- Standard base mounting
- Conversion set for hoisting

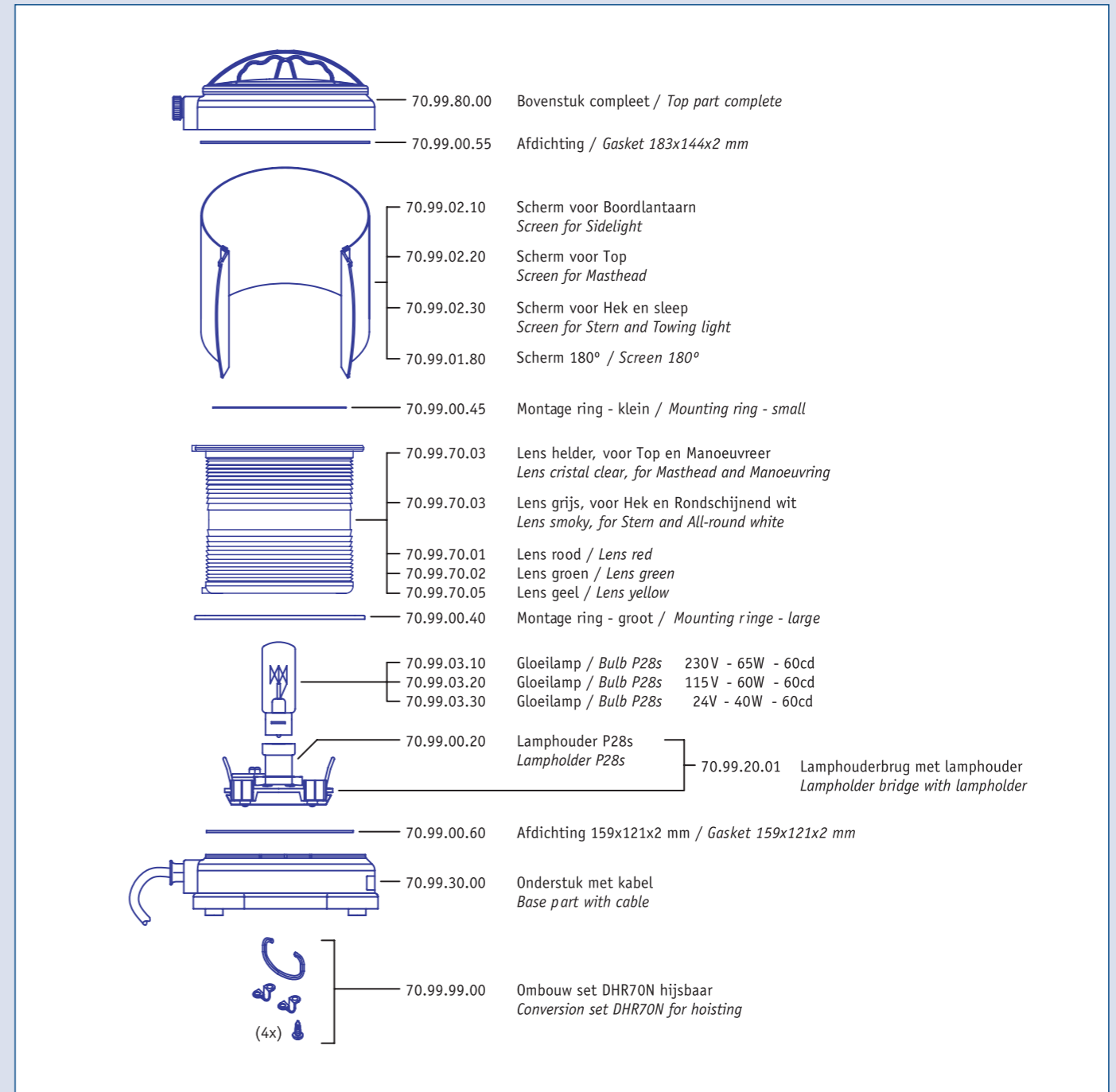
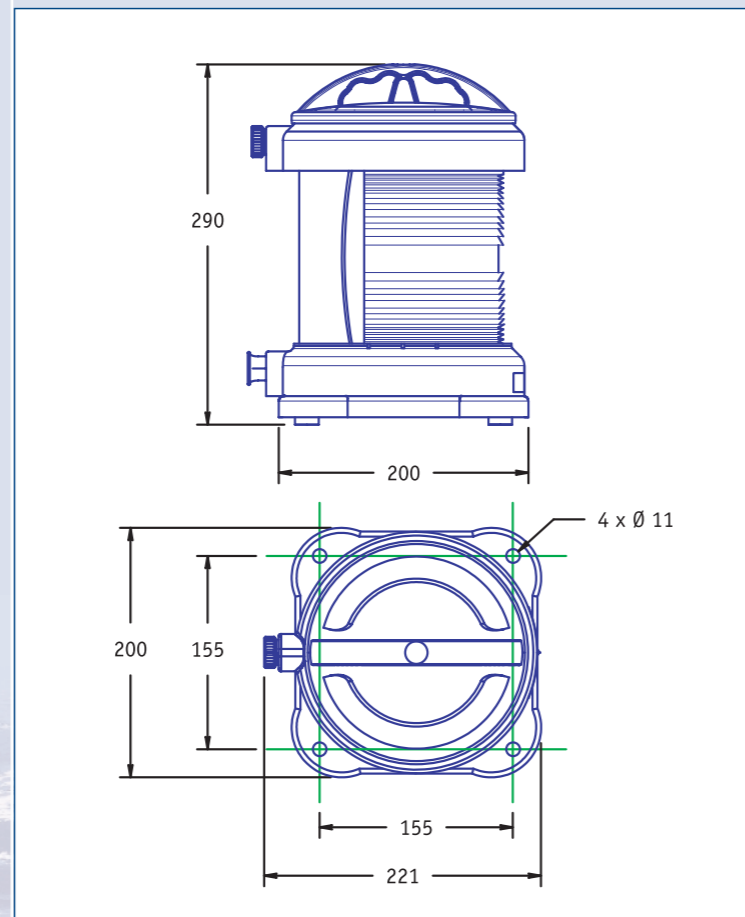

Soort sector	Type Sectional	ART. CODE	KG	Goedkeuring Approval	Min. zichtbaarheid Min. Visibility
Stuurboord	Starboard	70.11.00.00	2.6	COLREG'72 - RPR/BPR	3 N.M.
Bakboord	Port	70.12.00.00	2.6	COLREG'72 - RPR/BPR	3 N.M.
Top	Masthead	70.13.00.00	2.6	COLREG'72	6 N.M.
Hek	Stern	70.14.00.00	2.6	COLREG'72 - RPR/BPR	3 N.M.
Hek - rood	Stern - red	70.14.17.00	2.6	Suez kanaal / Suez Canal	3 N.M.
Sleep	Towing	70.15.00.00	2.6	COLREG'72	3 N.M.
Rondschijsend*	All-round	ART. CODE	KG	Goedkeuring Approval	Min. zichtbaarheid Min. Visibility
Wit 3 Z.M.	White 3 N.M.	70.16.00.00	2.3	COLREG'72 - RPR/BPR	3 N.M.
Wit 5 Z.M.	White 5 N.M.	70.16.10.00	2.3	COLREG'72	5 N.M.
Rood	Red	70.17.00.00	2.3	COLREG'72 - RPR/BPR	3 N.M.
Groen	Green	70.18.00.00	2.3	COLREG'72 - RPR/BPR	3 N.M.
Geel	Yellow	70.19.00.00	2.3	COLREG'72	3 N.M.

*Ook verkrijgbaar met 180 -Scherm *Also available with 180 -Screen