

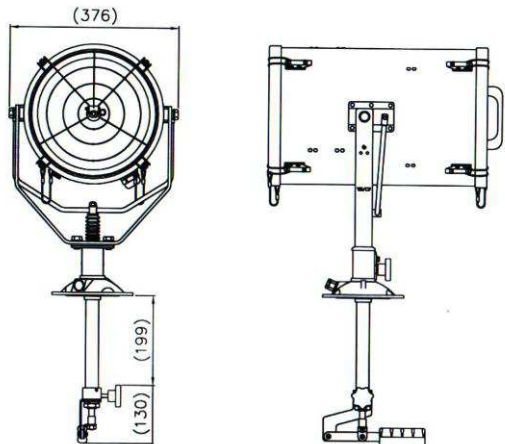

LX300 Issue 3
Xenon 150 w
Manual Control

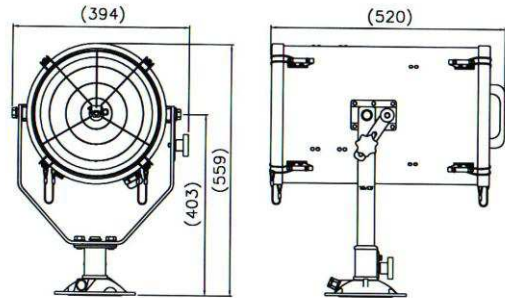

APPLICATION

THE HIGH PERFORMANCE FRANCIS LX range of searchlights incorporate the design features required to successfully operate searchlights in the most demanding product operating environments on land and sea.

Within the Francis Lite range of marine searchlights, the LX300, utilising a 150w xenon lamp, has been designed to give maximum beam range and candlepower, which DC incandescent halogen lamps are unable to achieve. Having the ability to identify objects and potential dangers from a far greater distance, the LX300 can prevent both vessel and lives being put to risk. As an optional extra, this unit is also available with infra-red night vision ensuring total covert surveillance

SPECIFICATION

- Immediate full lamp brilliance from switch on.
- Instant re-strike. No "cooling" down time required.
- Toughened front glass.
- Parabolic aluminium reflector.
- Economical 1200 hour lamp life.
- Constructed from stainless steel with stove enamel paint finish
- Spill rings to prevent glare and stray
- Operational temperature -50°C.
- Vertical movement +25° to - 25° (Cabin/Cabin Ped).
- Vertical movement +40° to - 35° (Deck/Deck Ped).
- Impressive 450° rotation.
- Sealing - IP66 Searchlight, IP67 PSU.
- Searchlight weight deck 16.9 Kgs, PSU weight 2.7 kgs
- Under deck mechanism 2.3Kgs.
- Range 2465m
- Peak Beam Candle Power 6 million
- Optional infa red filter
- Lamp part number D8151

All dimensions in Millimeters

BASE FIXING DETAILS:

4 HOLES 11 DIA EQUI-SPACED ON A 154mm PCD.
Cabin Centre hole 75mm

Type	Supply	Watts	Part No
LX300D	24 V DC	150 w	A2476
LX300 D	110/220v	150w	A2418

Cabin Control assembly - C23175-001

For more information contact:

Francis Searchlights Limited
Union Road, Bolton, BL2 2HJ, UK
Tel 44 (0) 1204 558960 Fax 44 (0) 1204 558979
Email sales@francis.co.uk Web site www.francis.co.uk