



LX480RC Prison Grade Iss. 2
Xenon 1KW, Variable
Speed, Remote Control



APPLICATION

The new FRANCIS LX Prison and Security grade of Remote Controlled Searchlights incorporate the design features required to successfully operate searchlights in the most demanding product operating environments. Manufactured from the most robust materials and using a precision electro formed nickel reflector, which is virtually indestructible and will not shatter if hit by bullets.

These Prison Searchlights have been further developed and improved by adding full variable speed, a new joystick control panel, using membrane and LED technology, offering RS485 interface and an auto home position setting, all at no extra cost.

The Xenon offers a colour temperature similar to daylight, and offers exceptional illumination, especially in long range security applications.

These units have been installed at many high security and sensitive locations throughout the world and is approved by various armies including UK, US, European, and various Middle Eastern customers.

SPECIFICATION

- Immediate full lamp brilliance from switch on.
- Instant re-strike. No "cooling" down time required.
- Toughened front glass. Optional metal guard available.
- Precision electro formed nickel reflector
- Constructed from high grade materials and fixings
- Powder coated and stove enamel paint finish.
- Remote pan rotation 385° with tilt /elevation control $\pm 40^\circ$.
- Variable speed LED joystick, with auto home position and RS485 connectivity.
- Variable Rotation Speed 1 to 20°/sec (Pan)
- Variable Elevation Speed 1 to 10°/sec (Tilt).
- Heaters fitted in barrel and gearbox, operational temp -50°
- Remote lamp focus, 1.5° spot to 10° flood.
- High quality Electronic PSU suitable for 50/60 Hz 1ph
- Sealing - IP66 Gearbox, IP56 Searchlight, PSU IP56
- Searchlight weight 66 kgs, Power supply weight 14kgs .

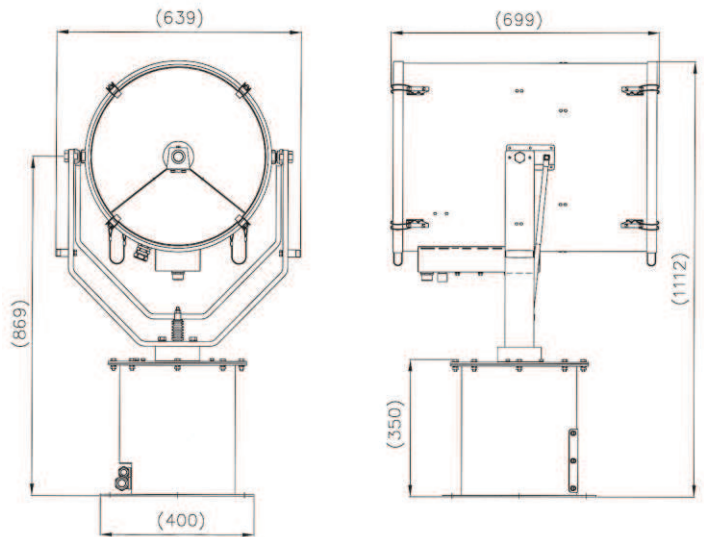

ALL DIMENSIONS IN MILLIMETRES

Base fixing details:

4 holes 12.5 \varnothing equi-spaced on a 350mm PCD
Joystick panel 120 x 120mm (106 x 106mm cutout)

PSU dimensions : 430 X 330 X 217mm

Part Numbers

Type	Supply	Watts	Part No	Lamp No
LX480RC	230v	1kw	A7056	D6780
LX480RC	115v	1kw	A7055	D6780

VAC	Lamp life	Range @ 1 Lux	PBCP X 1000	Div	Watts
115/230v	2000 hrs	9,500m	77,000	1.5°	1000w

Francis Searchlights Limited
Union Road, Bolton, BL2 2HJ, UK
Tel 44 (0) 1204 558960 Fax 44 (0) 1204 558979
Email sales@francis.co.uk Web site www.francis.co.uk

For more information contact:

Francis making the world a safer place.